

FEATURES & DIP-SWITCH SET-UP

EVOLUX2

Light source	LED 5000K >500cd/m ² (white luminance) >200cd/m ² (average luminance)
Installed load	5.8W/6.1VA (maintained M) 2.0W/3.9VA (non-maintained NM) 5.7W/6.0VA (CBS)
Protection index	IP40
Viewing distance	28m-39m



Most advanced "V" twin LED light source with perfect light distribution. It is equipped with high efficient (150lm/W) LONGLIFE LEDs with the lifetime min 100.000h

Progresívny svetelný zdroj s perfektnou distribúciou svetla je vybavený dlhoživotnými LED (min 100000 hod) s účinnosťou 150lm/W



Both the mirror-effect >94% reflector shape and body shape ensure perfect lighting characteristics. Thanks to the wide lighting distribution curves you need less SEC emergency lighting fixtures than the standard ones to achieve 1x even emergency lighting illumination level.

Geometria vysokolešteného >94% hliníkového reflektoru a telesa svietidla zaručujú dokonalé svetelno-technické parametre svietidla. Vďaka širokej krivke svietivosti je potrebný menší počet svietidiel pre dosiahnutie rovnomerného osvetlenia v porovnaní s bežnými svietidlami.



Perfect Modern Orientated Shape allowing you to use it in all kind of applications

Perfektný tvar telesa svietidla ho predurčuje k použitiu v moderných interiéroch súčasnosti

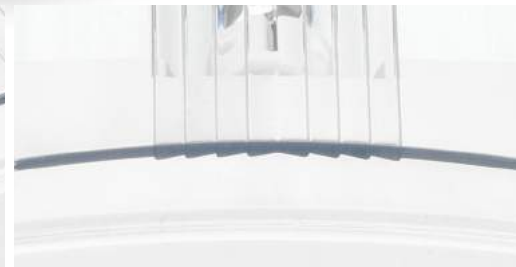

Linear Fresnel Lens

Lineárna Fresnelova šošovka

CHARG BAT LED TEST

AUTOTEST/CENTRALTEST
(only MULTIEVO-AT/ATXL/ATRF):
Monitor status by 3x LEDs and TEST button

AUTOTEST/CENTRALTEST
(len MULTIEVO-AT/ATXL/ATRF)
3x LED pre signalizáciu stavu svietidla
a TEST tlačítko



ENERGY SAVING
ECO MODE
SET UP



2/200
cd/m²

DIP SWITCH FEATURES No.1-4

DIP PREPÍNAČ č.1-4 - FUNKCIE

SELF-CONTAINED BATTERY VERSIONS

NORMAL MODE
230V MAINS

EMERGENCY MODE
BATTERY

1 LUX
ESCAPE ROUTE
APPLICATION

1 LUX
ESCAPE ROUTE
APPLICATION



NO LEGEND / BEZ PIKTOGRAMU
ESCAPE ROUTE ILLUMINATION

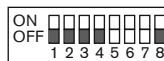

DEFAULT SETT./ PREDNASTAVENÉ
Full Power for ESCAPE SIGN Applicaton
BRIGHTNESS > 200cd/m²

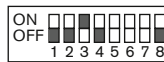

ECO MODE 50% (in 230V mode)
EMERGENCY MODE LEGEND
BRIGHTNESS > 200cd/m²



ECO MODE 25% (in 230V mode)
EMERGENCY MODE LEGEND
BRIGHTNESS > 200cd/m²



ECO MODE 10% (in 230V mode)
EMERGENCY MODE LEGEND
BRIGHTNESS > 200cd/m²

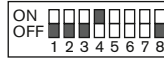

ENERGY SAVING (in emerg.mode)
LEGEND BRIGHTNESS > 2cd/m²
JAS PIKTOGRAMU > 2cd/m²

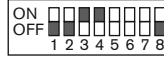

ENERGY SAVING (in emerg.mode)
ECO MODE 50% (in 230V mode)
LEGEND BRIGHTNESS > 2cd/m²

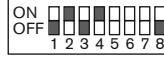

ENERGY SAVING (in emerg.mode)
ECO MODE 25% (in 230V mode)
LEGEND BRIGHTNESS > 2cd/m²



ENERGY SAVING (in emerg.mode)
ECO MODE 10% (in 230V mode)
LEGEND BRIGHTNESS > 2cd/m²



M /
NM

AT /
ATXL

NO
AT

DIP SWITCH FEATURES No.5-8

DIP PREPÍNAČ č.5-8 - FUNKCIE



**INSTALLATION
MODE**
SET UP

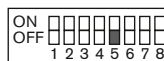

DEFAULT SETTING / PREDNASTAVENÉ
OFF - ACTIVATED
ON - DEACTIVATED

M /
NM

**NON-MAINTAINED /
MAINTAINED
MODE**
SET UP

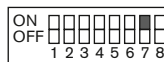

DEFAULT SETTING / PREDNASTAVENÉ
ON - MAINTAINED
OFF - NON-MAINTAINED

AT /
ATXL

**AUTOTEST /
CENTRALTEST
MODE**
SET UP

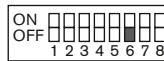

DEFAULT SETTING / PREDNASTAVENÉ
OFF - AUTOTEST
ON - CENTRALTEST

NO
AT

**NO-AUTOTEST
MODE**
SET UP



DEFAULT / PREDNASTAVENÉ
OFF - AUTOTEST ACTIVE
ON - NO-AUTOTEST

TO SEE THE CHANGE PUSH EITHER TEST BUTTON OR DISCONNECT THE FIXTURE FROM BOTH THE MAINS 230V AND BATTERY

Po prestavení stlačte TEST alebo odpojte batériu a 230V napájanie na aktiváciu zmeny

DIP SWITCH FEATURES No.2-3

DIP PREPÍNAČ č.2-3 - FUNKCIE

CBS CENTRAL BATTERY VERSIONS

**CBS
CENTRAL BATTERY**

1 LUX
ESCAPE ROUTE
APPLICATION



FULL POWER
PLNÝ VÝKON



FULL POWER
LEGEND BRIGHTNESS > 200cd/m²
JAS PIKTOGRAMU > 200cd/m²

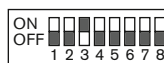

ECO MODE 50%

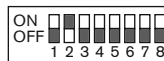

ECO MODE 25%



ECO MODE 10%
LEGEND BRIGHTNESS > 2cd/m²
JAS PIKTOGRAMU > 2cd/m²

TO SEE THE CHANGE PUSH EITHER TEST BUTTON OR DISCONNECT THE FIXTURE FROM BOTH THE MAINS 230V AND BATTERY

Po prestavení stlačte TEST alebo odpojte batériu a 230V napájanie na aktiváciu zmeny

CHARG BAT TUBE TEST
Yellow LED Blinking = TEST mode

There are in total 5 cable entries: 4 side ones
around the body and 1 from the back side.

Na telese svietidla sa nachádzajú 4x
prechodky po obvode svietidla a 1x zo zadnej
strany telesa svietidla.

FEATURES EVOLUX2

An elegant design, high efficiency and a pictogram viewing distance range up to 39m - these are the outer features of EVOLUX2 emergency lighting fixture type series. Combined with the qualities of an innovative LED light source - extra-long service life at constant light output - this escape sign luminaire boasts a special talent for low operating costs. The luminaire proves its application flexibility with its range of installation options.

Elegantný design, vysoká účinnosť a rozpoznateľnosť piktogramu až 39m - to sú extra vlastnosti typovej rady EVOLUX2. V kombinácii s kvalitami inovatívneho LED svetelného zdroja - extra dlhá životnosť pri konštantnom svetelnom výkone - sa môže toto núdzové svietidlo pochváliť špeciálnym talentom pre nízke prevádzkové a servisné náklady. EVOLUX2 dokazuje svoju aplikačnú flexibilitu vďaka širokej typovej rade s rôznymi inštaláčnymi možnosťami.

Light source	LED 5000K
	>500cd/m ² (white luminance)
	>200cd/m ² (average luminance)
Installed load	5.8W/6.1VA (maintained M)
	2.0W/3.9VA (non-maintained NM)
	5.7W/6.0VA (CBS)
Protection index	IP40
Viewing distance	28m-39m



Most advanced "V" twin LED light source with perfect light distribution. It is equipped with high efficient (150lm/W) LONGLIFE LEDs with the lifetime min 100.000h



C.EVOLUX2-P LED MULTIEVO2-P-AT LED

brightens escape routes at every step and turn

Wall or ceiling mounting LED emergency luminaire for escape route lighting in accordance with EN1838
Maximum luminaire spacing: up to 14,8m>1lx

LED núdzové svietidlo pre montáž na stenu alebo strop pre osvetlenie únikovej cesty v súlade s EN1838
Maximálny rozostup svietidiel: až 14,8m>1lx



C.EVOLUX2-P LED (with ISO7010 pictogram in AL frame) MULTIEVO2-P-AT LED (with ISO7010 pictogram in AL frame)

escape sign luminaire

LED AL frame legend escape sign emergency luminaire in accordance with EN1838
Legend luminance: >500cd/m² (white)
Viewing distance: 28m

LED núdzové svietidlo s piktogramom v AL rámičku (v súlade s EN1838)
Jas piktogramu: >500cd/m² (biela)
Rozoznatelnosť piktogramu: 28m



C.EVOLUX2-P LED (with self-adhesive picto) MULTIEVO2-P-AT LED (with self-adhesive picto)

escape sign luminaire

LED escape sign emergency luminaire in accordance with EN1838 (self-adhesive pictogram)
Legend luminance: >500cd/m² (white)
Viewing distance: 39m

LED núdzové svietidlo so samolepiacim piktogramom (v súlade s EN1838)
Jas piktogramu: >500cd/m² (biela)
Rozoznatelnosť piktogramu: 39m

**C.EVOLUX2-V LED
MULTIEVO2-V-AT LED**
escape route anti-panic lighting

Recessed mounting LED emergency anti-panic luminaire in accordance with EN1838
Maximum luminaire 1lx spacing: up to 14,8m>1lx
LED núdzové svietidlo pre montáž do stropu pre osvetlenie únikovej cesty v súlade s EN1838
Maximálny rozostup svietidiel na 1lx: až 14,8m>1lx



**C.EVOLUX2-PP LED
MULTIEVO2-PP-AT LED**
escape sign & escape route anti-panic lighting

Ceiling mounting LED emergency anti-panic luminaire in combination with suspended plexi with pictogram in accordance with EN1838
Viewing distance: 34m
Maximum luminaire 1lx spacing: up to 14,8m>1lx
LED núdzové svietidlo pre montáž na strop v kombinácii so závesným plexi s piktogramom pre osvetlenie únikovej cesty v súlade s EN1838
Rozoznatelnosť piktogramu: 34m
Maximálny rozostup svietidiel na 1lx: až 14,8m>1lx



**C.EVOLUX2-PP LED
MULTIEVO2-PP-AT LED**
escape sign with AL frame

Ceiling mounting LED emergency escape sign luminaire with suspended plexi with pictogram in accordance with EN1838
Viewing distance: 34m
LED núdzové svietidlo pre montáž na strop so závesným plexi s piktogramom súlade s EN1838
Rozoznatelnosť piktogramu: 34m



**C.EVOLUX2-VP LED
MULTIEVO2-VP-AT LED**
escape sign & escape route anti-panic lighting

Recessed mounting LED emergency anti-panic luminaire in combination with suspended plexi with pictogram in accordance with EN1838
Viewing distance: 34m
Maximum luminaire 1lx spacing: up to 14,8m>1lx
LED núdzové svietidlo pre montáž do stropu v kombinácii so závesným plexi s piktogramom pre osvetlenie únikovej cesty v súlade s EN1838
Rozoznatelnosť piktogramu: 34m
Maximálny rozostup svietidiel na 1lx: až 14,8m>1lx



**C.EVOLUX2-VP LED
MULTIEVO2-VP-AT LED**
escape sign with AL frame

Recessed mounting LED emergency escape sign luminaire with suspended plexi with pictogram in accordance with EN1838
Viewing distance: 34m
LED núdzové svietidlo pre zapustenú montáž do stropu so závesným plexi s piktogramom súlade s EN1838
Rozoznatelnosť piktogramu: 34m



SURFACE WALL OR CEILING EVOLUX2-P

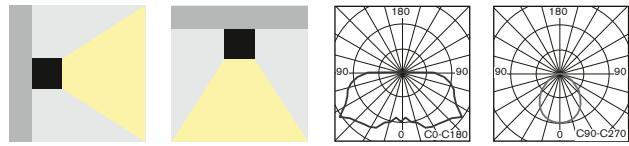

• Euisite design surface mounted powerful LED fixture with perfect light distribution for non-maintained/maintained (NM/M) or centralised (C) emergency lighting available in all following versions:

- **AUTOTEST** (-AT)
- **DALI**
- **CENTRALTEST** (-ATXL) for ELMAX-Look Mini system (look up page No.36)
- **CENTRAL BATTERY** (C.EVOLUX2) for **non-addressable CBS** (look up also page No.44)
- **CENTRAL BATTERY** (-ATXP) for system **ELMAX-PATROLUX Mini & Addressable CBS** (look up also page No.40)
- Conforming to the requirement of EN60598-2-22, EN1838, EN62034
- Design: Anodized AL base & PC impact resistant diffuser

• Elegantné výkonné LED núdzové svietidlá s perfektnou distribúciou svetla pre trvalé/netrvalé (NM/M) alebo (C) centrálné napájané núdzové osvetlenie dostupné vo verziách pre:

- **AUTOTEST** (-AT) alebo **DALI**,
- **CENTRALTEST** (-ATXL) pre systém ELMAX-LOOK Mini (pozri str.36)
- **CENTRAL BATTERY** (C.EVOLUX2) pre **neadresovateľné CBS** (str.44)
- **CENTRAL BATTERY** (-ATXP) pre systém **ELMAX-PATROLUX Mini s adresovateľnou CBS** (pozri str. 40)

- spĺňa požiadavky európskej normy EN 60598-2-22, EN1838, EN62034
- konštrukcia: teleso z eloxovaného hliníku a svetelno-činný kryt z nerozbitného PC

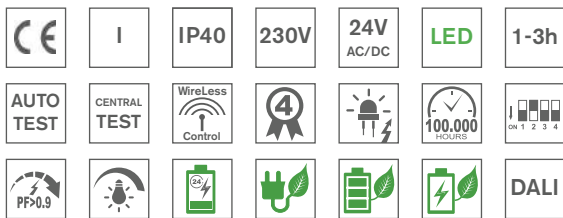

Input Power:

- 5,8W/ 6,1VA (maintained M)
- 2,0W/ 3,9VA (non-maintained NM)
- 5,7W/ 6,0VA (CBS)

STANDARD FEATURES

STANDARDNÁ VÝBAVA

- **High efficient (150lm/W) LONGLIFE LEDs 5000K (>100.000h)**
- **NEW Advanced Electronics**
- **LONGLIFE LiFePo4 battery**
- **Installation Mode** (battery protection, for more details look up page No.50-51)
- **Intelligent battery charging** (intermittent charging, look up page No.50-51)
- **DIP Switch** allowing to preset following functions:
 - **ECO Mode** (dimming 10%-100%, for more details look up page No.50-51)
 - **ENERGY Saving Mode** (picto illumination 2cd/m² or 200cd/m², look up page 551)
- Special mirror effect reflector
- Addressable CENTRALTEST communication module (for ATXL, ATXP only)
- LEDs indicating both presence of power supply and signaling failures + TEST button
- **vysoko účinné LED 5000K (150lm/W) so životnosťou min.100000h**
- **progressívna elektronická jednotka**
- **LONGLIFE LiFePo4 batéria**
- **Inštalovaný mód** (ochrana batérie, pozri aj str.50-51)
- **Inteligentné nabíjanie batérie** ("intermittent" nabíjanie, pozri aj str.50-51)
- **DIP prepínač** umožňujúci prednastavenie funkcií:
 - **ECO Mód** (stmievanie 10%-100%, pozri aj str.50-51)
 - **ENERGY Saving Mód** (osvetlenie picto na 2cd/m² alebo 200cd/m², pozri aj str.51)
- špeciálny odrazový reflektor so zrkadlovým efektom
- adresovateľný CENTRALTEST komunikačný modul (len pre ATXL, ATXP verzie)
- signalizácia LED a TEST tlačítko

OPTIONAL ACCESSORIES

PRÍPLATKY

- Pictograms / Legends (look up page No.58)
- Wall or ceiling mounting brackets (look up page No.58)
- Protective steel cage (look up page No.58)
- samolepiace alebo fóliové piktogramy s AL rámkom (pozri str.58)
- nástenná, stropná alebo stropná závesná konzola (pozri str.58)
- ochranný kovový kôš (pozri str.58)

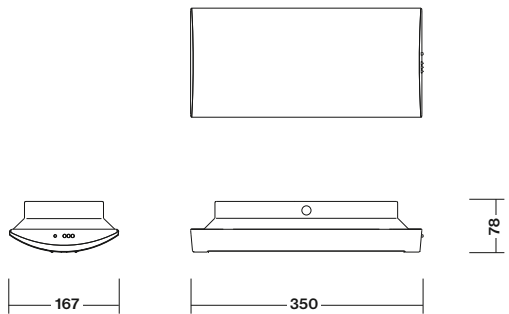

Most Advanced Twin "V" shaped LED light source for perfect light distribution
Progressívny svetelný zdroj s usporiadaním LED do tvaru "V" s perfektnou distribúciou svetla a vysokou účinnosťou



Optional AL Frame with + Foil Legends
Príplatkový AL rámik s piktogramom (look up also page No.58)



Optional Self-adhesive Legends
Príplatkové samolepiace piktogramy (look up also page No.58)

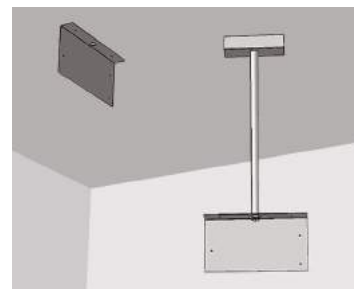

Optional Brackets and Protective Cage
Príplatková konzola a ochranná mreža (look up also page No.58)

Shopping area emergency lighting application



Page No.32

AUTOTEST -AT NM/M

Type	Version	Duration	Light Source	Light Flux / Emergency mode	Battery	Order Code	Weight
MULTIEVO2-P-AT.1h	NM/M	1h	LED	350 lm / 310 lm	LiFePo4 6,4V/1,0Ah	290-B-001-04-00-00	1,5 kg
MULTIEVO2-P-AT.3h	NM/M	3h	LED	350 lm / 310 lm	LiFePo4 6,4V/2,0Ah	290-B-002-04-00-00	1,6 kg

DALI Self-Contained

Type	Version	Duration	Light Source	Light Flux / Emergency mode	Battery	Order Code	Weight
MULTIEVO2-P-DALI.1h	NM/M	1h	LED	350 lm / 310 lm	LiFePo4 6,4V/1,0Ah	290-B-008-04-00-00	1,7 kg
MULTIEVO2-P-DALI.3h	NM/M	3h	LED	350 lm / 310 lm	LiFePo4 6,4V/2,0Ah	290-B-010-04-00-00	1,7 kg

Page No.36

CENTRALTEST -ATXL ELMAX-LOOK

Type	Version	Duration	Light Source	Light Flux / Emergency mode	Battery	Order Code	Weight
MULTIEVO2-P-ATXL.1h	NM/M	1h	LED	350 lm / 310 lm	LiFePo4 6,4V/1,0Ah	290-B-003-04-00-00	1,6 kg
MULTIEVO2-P-ATXL.3h	NM/M	3h	LED	350 lm / 310 lm	LiFePo4 6,4V/2,0Ah	290-B-004-04-00-00	1,7 kg

Page No.38

CENTRALTEST -ATRF ELMAX-WIRELESS

Type	Version	Duration	Light Source	Light Flux / Emergency mode	Battery	Order Code	Weight
MULTIEVO2-P-ATRF.1h	NM/M	1h	LED	350 lm / 310 lm	LiFePo4 6,4V/1,0Ah	290-B-011-04-00-00	1,6 kg
MULTIEVO2-P-ATRF.3h	NM/M	3h	LED	350 lm / 310 lm	LiFePo4 6,4V/2,0Ah	290-B-009-04-00-00	1,7 kg

DALI CENTRAL BATTERY (CBS)

Type	Version	Light Source	Light Flux	Order Code	Weight
C.EVOLUX2-P DALI 230V AC	DALI CBS	LED	650 lm	290-B-012-00-00-00	1,2 kg

Page No.44

CENTRAL BATTERY (CBS)

Type	Version	Light Source	Light Flux	Order Code	Weight
C.EVOLUX2-P 230V AC/DC	CBS NON-ADDRESSABLE	LED	760 lm	290-B-006-00-00-00	1,2 kg
C.EVOLUX2-P 24V AC/DC	CBS NON-ADDRESSABLE	LED	760 lm	290-B-007-00-00-00	1,2 kg

Page No.40

Addressable CENTRAL BATTERY (CBS) -ATXPR ELMAX-PATROLUX

Type	Version	Light Source	Light Flux	Order Code	Weight
C.EVOLUX2-P-ATXPR 230V AC/DC	ATXPR CBS ADDRESSABLE	LED	760 lm	290-B-005-00-00-00	1,2 kg

Look up pages No. 210-217 for 1x Spacing tables
Pozri str.210-217 pre rozmiestnenie svetidiel na dosiahnutie 1x

ACCESSORIES EVOLUX2-P



- Foil based legend + AL cover frame (click system) complying ISO7010
- Viewing Distance: 28m
- Legend luminance > 500cd/m² (white)
- fóliový piktogram + krycí AL rámik („klik“ systém) v súlade s ISO7010
- rozoznatelnosť piktogramu: 28m
- jas piktogramu > 500cd/m² (biela)

Optional Item / Príplatok	Order Code / Objednávaci kód
Foil picto „H“+AL Frame / pikto fólia „H“+rámik	102-B-00-52-01
Foil picto „I“+AL Frame / pikto fólia „I“+rámik	102-B-00-48-01
Foil picto „J“+AL Frame / pikto fólia „J“+rámik	102-B-00-50-01
Foil picto „K“+AL Frame / pikto fólia „K“+rámik	102-B-00-55-01
Foil picto „L“+AL Frame / pikto fólia „L“+rámik	102-B-00-56-01
Foil picto „M“+AL Frame / pikto fólia „M“+rámik	102-B-00-53-01
Foil picto „N“+AL Frame / pikto fólia „N“+rámik	102-B-00-54-01
Foil picto „O“+AL Frame / pikto fólia „O“+rámik	102-B-00-59-01
Foil picto „Z1“+AL Frame / pikto fólia „Z1“+rámik	102-B-00-70-00
Foil picto „Z2“+AL Frame / pikto fólia „Z2“+rámik	102-B-00-71-00



- Self-adhesive legend complying ISO7010
- Viewing Distance 39m
- Legend luminance > 500cd/m² (white)
- samolepiaci piktogram v súlade s ISO7010
- rozoznatelnosť piktogramu 39m
- jas piktogramu > 500cd/m² (biela)

Optional Item / Príplatok	Order Code / objednávaci kód
Self-adhesive „H“ / samolepiaci piktogram „H“	V-102-SAM-01-00-04
Self-adhesive „I“ / samolepiaci piktogram „I“	V-102-SAM-01-00-05
Self-adhesive „J“ / samolepiaci piktogram „J“	V-102-SAM-01-00-06
Self-adhesive „O“ / samolepiaci piktogram „O“	V-102-SAM-01-00-92
Self-adhesive „Z1“ / samolepiaci piktogram „Z1“	V-102-SAM-01-00-136
Self-adhesive „Z2“ / samolepiaci piktogram „Z2“	V-102-SAM-01-00-36

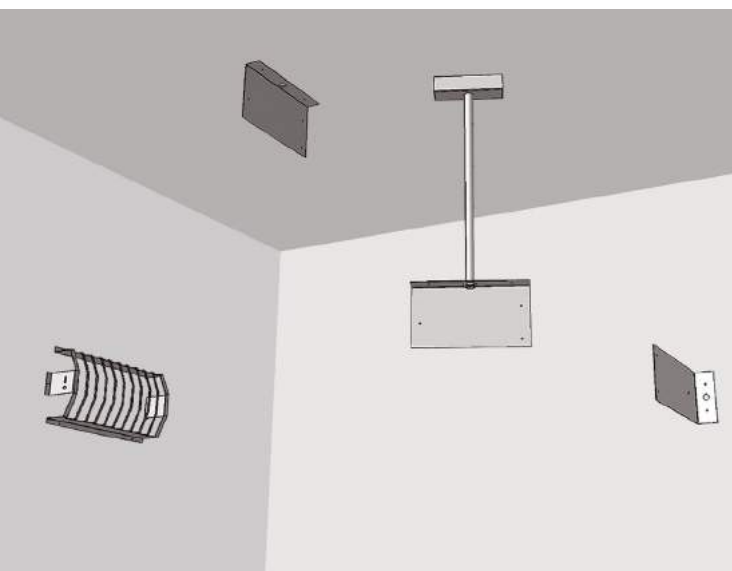

Options:

- Wall / Ceiling / Pendant mounting bracket
- Protective Steel Cage

Príplatky:

- nástenná / stropná / závesná konzola
- ochranný kôš

Optional Item / Príplatok	Order Code / objednávaci kód
Wall mounting bracket / nástenná konzola	102-B-01-09-01
Ceiling mounting bracket / stropná konzola	102-B-01-08-01
Pendant bracket 0,5m / závesná konzola 0,5m	102-B-28-02-00
Pendant bracket 1,0m / závesná konzola 1,0m	102-B-28-03-00
Pendant bracket 1,5m / závesná konzola 1,5m	102-B-28-04-00
Protective steel cage / ochranný kôš	102-B-00-29-00

Shopping area emergency lighting application



CEILING MOUNTING READY FOR SUSPENDED LEGEND EVOLUX2-PP

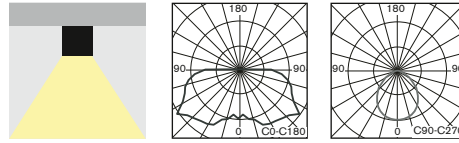

- Equisite design surface mounted powerful LED fixture with perfect light distribution ready for suspended plexi legend
- Designed for non-maintained/maintained (NM/M) or centralised (C) emergency lighting available in all following versions:

- **AUTOTEST** (-AT)
- **DALI**
- **CENTRALTEST** (-ATXL) for ELMAX-Look Mini system (look up page No.36)
- **CENTRAL BATTERY** (C.EVOLUX2) for **non-addressable CBS** (page 44)
- **CENTRAL BATTERY** (-ATXP) for system **ELMAX-PATROLUX Mini & Addressable CBS** (look up page No. 40)
- Conforming to the requirement of EN60598-2-22, EN1838, EN62034
- Design: Anodized AL base & PC impact resistant diffuser

- Elegánntné výkonné LED núdzové svietidlo s perfektnou distribúciou svetla pre trvalé/netrvalé (NM/M) alebo (C) centrálné napájané núdzové osvetlenie dostupné vo verziách pre:

- **AUTOTEST** (-AT)
- **DALI**
- **CENTRALTEST** (-ATXL) pre systém ELMAX-LOOK Mini (pozri str.36)
- **CENTRAL BATTERY** (C.EVOLUX2) pre **neadresovateľné CBS** (str. 44)
- **CENTRAL BATTERY** (-ATXP) pre systém **ELMAX-PATROLUX Mini s adresovateľnou CBS** (pozri str. 40)

- spĺňa požiadavky európskej normy EN 60598-2-22, EN1838, EN62034
- konštrukcia: teleso z eloxovaného hliníku a svetelno-činný kryt z nerozbitného PC

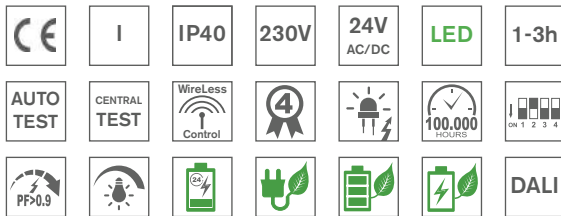

Input Power:

- 5,8W/ 6,1VA (maintained M)
- 2,0W/ 3,9VA (non-maintained NM)
- 5,7W/ 6,0VA (CBS)

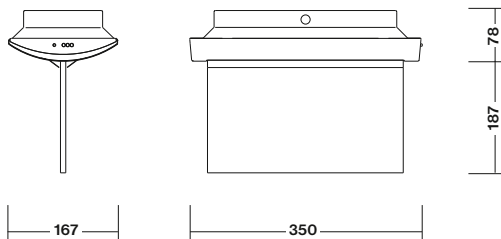

STANDARD FEATURES

STANDARDNÁ VÝBAVA

- **High efficient (150lm/W) LONGLIFE LEDs 5000K (>100.000h)**
- **NEW Advanced Electronics**
- **LONGLIFE LiFePo4 battery**
- **Installation Mode** (battery protection, for more details look up page No.50-51)
- **Intelligent battery charging** (intermittent charging, look up page No.50-51)
- **DIP Switch** allowing to preset following functions:
 - **ECO Mode** (dimming 10%-100%, for more details look up page No.50-51)
 - **ENERGY Saving Mode** (picto illumination 2cd/m² or 200cd/m², look up page 51)
- Special mirror effect reflector
- Addressable CENTRALTEST communication module (for ATXL, ATXP only)
- LEDs indicating both presence of power supply and signaling failures & TEST button
- **vysoko účinné LED 5000K (150lm/W) so životnosťou min.100000h**
- **progressívna elektronická jednotka**
- **LONGLIFE LiFePo4 batéria**
- **Inštalovaný mód** (ochrana batérie, pozri aj str.50-51)
- **Intelligentné nabíjanie batérie** ("intermittent" nabíjanie, pozri aj str.50-51)
- **DIP prepínač** umožňujúci prednastavenie funkcií:
 - **ECO Mód** (stmievanie 10%-100%, pozri aj str.50-51)
 - **ENERGY Saving Mód** (osvetlenie piko na 2cd/m² alebo 200cd/m², pozri aj str.51)
- špeciálny odrazový reflektor so zrkadlovým efektom
- adresovateľný CENTRALTEST komunikačný modul (len pre ATXL, ATXP verzie)
- signalizácia LED a TEST tlačítko

OPTIONAL ACCESSORIES

PRÍPLATKY

- Suspended plexi with double sided or single sided legends (look up page No.64)
- Suspended mounting ceiling brackets (look up page No.64)
- AL cover frame for light beam direction to the plexi with legend (look up page No.64)
- závesné plexi s jednostranným alebo obojstranným piktogramom (pozri str.64)
- stropná závesná konzola (pozri str.64)
- hliníkový rámik pre nasmerovanie svetla len do plexi hrany (pozri str.64)



Most Advanced Twin "V" shaped LED light source for perfect light distribution and high efficiency
Progressívny svetelný zdroj s usporiadaním LED do tvaru "V" s perfektnou distribúciou svetla a vysokou účinnosťou



Optional Suspended Plexi Legends and AL Frame
Príplatkové závesné plexi s piktogramom a AL rámik (look up also page No.64)

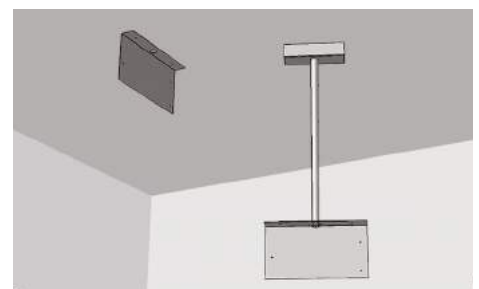

Optional Brackets
Príplatkové konzoly (look up also page No.64)

CEILING MOUNTING READY FOR SUSPENDED LEGEND
EVOLUX2-PP

Shopping area emergency lighting application



Page No.32

AUTOTEST -AT NM/M

Type	Version	Duration	Light Source	Light Flux / Emergency mode	Battery	Order Code	Weight
MULTIEVO2-PP-AT.1h	NM/M	1h	LED	350 lm / 310 lm	LiFePo4 6,4V/1,0Ah	290-B-100-04-00-00	1,5 kg
MULTIEVO2-PP-AT.3h	NM/M	3h	LED	350 lm / 310 lm	LiFePo4 6,4V/2,0Ah	290-B-101-04-00-00	1,6 kg

DALI Self-Contained

Type	Version	Duration	Light Source	Light Flux / Emergency mode	Battery	Order Code	Weight
MULTIEVO2-PP-DALI.1h	NM/M	1h	LED	350 lm / 310 lm	LiFePo4 6,4V/1,0Ah	290-B-108-04-00-00	1,7 kg
MULTIEVO2-PP-DALI.3h	NM/M	3h	LED	350 lm / 310 lm	LiFePo4 6,4V/2,0Ah	290-B-109-04-00-00	1,7 kg

Page No.36

CENTRALTEST -ATXL ELMAX-LOOK

Type	Version	Duration	Light Source	Light Flux / Emergency mode	Battery	Order Code	Weight
MULTIEVO2-PP-ATXL.1h	NM/M	1h	LED	350 lm / 310 lm	LiFePo4 6,4V/1,0Ah	290-B-102-04-00-00	1,6 kg
MULTIEVO2-PP-ATXL.3h	NM/M	3h	LED	350 lm / 310 lm	LiFePo4 6,4V/2,0Ah	290-B-103-04-00-00	1,7 kg

Page No.38

CENTRALTEST -ATRF ELMAX-WIRELESS

Type	Version	Duration	Light Source	Light Flux / Emergency mode	Battery	Order Code	Weight
MULTIEVO2-PP-ATRF.1h	NM/M	1h	LED	350 lm / 310 lm	LiFePo4 6,4V/1,0Ah	290-B-110-04-00-00	1,6 kg
MULTIEVO2-PP-ATRF.3h	NM/M	3h	LED	350 lm / 310 lm	LiFePo4 6,4V/2,0Ah	290-B-111-04-00-00	1,7 kg

DALI CENTRAL BATTERY (CBS)

Type	Version	Light Source	Light Flux	Order Code	Weight
C.EVOLUX2-P DALI 230V AC	DALI CBS	LED	650 lm	290-B-105-00-00-00	1,2 kg

Page No.44

CENTRAL BATTERY (CBS)

Type	Version	Light Source	Light Flux	Order Code	Weight
C.EVOLUX2-PP 230V AC/DC	CBS NON-ADDRESSABLE	LED	760 lm	290-B-106-00-00-00	1,2 kg
C.EVOLUX2-PP 24V AC/DC	CBS NON-ADDRESSABLE	LED	760 lm	290-B-107-00-00-00	1,2 kg

Page No.40

Addressable CENTRAL BATTERY (CBS) -ATXPR ELMAX-PATROLUX

Type	Version	Light Source	Light Flux	Order Code	Weight
C.EVOLUX2-PP-ATXPR 230V AC/DC	ATXPR CBS ADDRESSABLE	LED	760 lm	290-B-104-00-00-00	1,2 kg

Look up pages No. 210-217 for 1lx Spacing tables
 Pozri str.210-217 pre rozmiestnenie svetidiel na dosiahnutie 1lx

EVOLUX2-VP

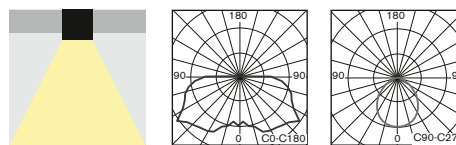

- Equisite design recessed mounted powerful LED fixture with perfect light distribution ready for suspended plexi legend
- Designed for non-maintained/maintained (NM/M) or centralised (C) emergency lighting available in all following versions:

- **AUTOTEST** (-AT)
- **DALI**
- **CENTRALTEST** (-ATXL) for ELMAX-Look Mini system (look up also page 36)
- **CENTRAL BATTERY** (C.EVOLUX2) for **non-addressable CBS** (page 44)
- **CENTRAL BATTERY** (-ATXP) for system **ELMAX-PATROLUX Mini & Addressable CBS** (look up also page No.40)
- Conforming to the requirement of EN60598-2-22, EN1838, EN62034
- Design: Anodized AL base & PC impact resistant diffuser

- Elegánntné výkonné LED núdzové svietidlo s perfektnou distribúciou svetla pre trvalé/netrvalé (NM/M) alebo (C) centrálné napájané núdzové osvetlenie dostupné vo verziách pre:

- **AUTOTEST** (-AT)
- **DALI**
- **CENTRALTEST** (-ATXL) pre systém ELMAX-LOOK Mini (pozri str.36)
- **CENTRAL BATTERY** (C.EVOLUX2) pre **neadresovateľné CBS** (str. 44)
- **CENTRAL BATTERY** (-ATXP) pre systém **ELMAX-PATROLUX Mini s adresovateľnou CBS** (pozri str. 40)

- spĺňa požiadavky európskej normy EN 60598-2-22, EN1838, EN62034
- konštrukcia: teleso z eloxovaného hliníku a svetelno-činný kryt z nerozbitného PC

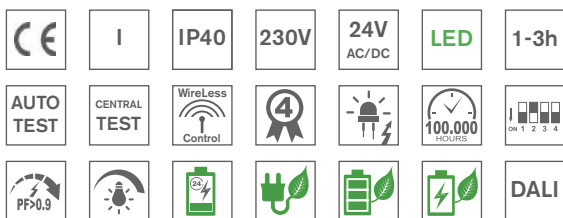

Input Power:

- 5,8W/ 6,1VA (maintained M)
- 2,0W/ 3,9VA (non-maintained NM)
- 5,7W/ 6,0VA (CBS)

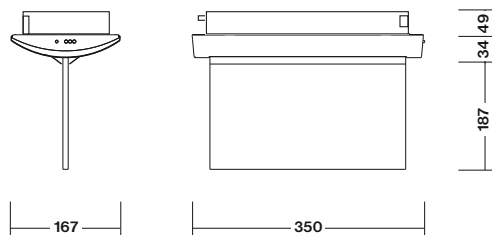

Recessed hole size 319x123mm
Rozmer montážneho otvoru 319x123mm

STANDARD FEATURES

STANDARDNÁ VÝBAVA

- **High efficient (150lm/W) LONGLIFE LEDs 5000K (>100.000h)**
- **NEW Advanced Electronics**
- **LONGLIFE LiFePo4 battery**
- **Installation Mode** (battery protection, for more details look up page No.50-51)
- **Intelligent battery charging** (intermittent charging, look up page No.50-51)
- **DIP Switch** allowing to preset following functions:
 - **ECO Mode** (dimming 10%-100%, for more details look up page No.50-51)
 - **ENERGY Saving Mode** (picto illumination 2cd/m² or 200cd/m², look up page 51)
- Special mirror effect reflector
- Addressable CENTRALTEST communication module (for ATXL, ATXP only)
- LEDs indicating both presence of power supply and signaling failures & TEST button
- **vysoko účinné LED 5000K (150lm/W) so životnosťou min.100000h**
- **progresívna elektronická jednotka**
- **LONGLIFE LiFePo4 batéria**
- **Inštalacný mód** (ochrana batérie, pozri aj str.50-51)
- **Inteligentné nabíjanie batérie** ("intermittent" nabíjanie, pozri aj str.50-51)
- **DIP prepínač** umožňujúci prednastavenie funkcií:
 - **ECO Mód** (stmievanie 10%-100%, pozri aj str.50-51)
 - **ENERGY Saving Mód** (osvetlenie pikto na 2cd/m² alebo 200cd/m², pozri aj str.51)
- špeciálny odrazový reflektor so zrkadlovým efektom
- adresovateľný CENTRALTEST komunikačný modul (len pre ATXL, ATXP verzie)
- signalizácia LED a TEST tlačítko

OPTIONAL ACCESSORIES

PRÍPLATKY

- Suspended plexi with double sided or single sided legends (look up page No.64)
- Suspended mounting ceiling brackets (look up page No.64)
- AL cover frame for light beam direction to the plexi with legend (look up page No.64)
- závesné plexi s jednostranným alebo obojstranným piktogramom (pozri str.64)
- stropná závesná konzola (pozri str.64)
- hliníkový rámik pre nasmerovanie svetla len do plexi hrany (pozri str.64)



Most Advanced Twin "V" shaped LED light source for perfect light distribution and high efficiency
Progresívny svetelný zdroj s usporiadaním LED do tvaru "V" s perfektnou distribúciou svetla a vysokou účinnosťou



Optional Suspended Plexi with Legends
Príplatkové závesné plexi s piktogramom (look up also page No.64)



Optional AL cover
Príplatkový hliníkový kryt (look up also page No.64)

RECESSED MOUNTING READY FOR SUSPENDED LEGEND
EVOLUX2-VP

Shopping area emergency lighting application



Page No.32

AUTOTEST -AT NM/M

Type	Version	Duration	Light Source	Light Flux / Emergency mode	Battery	Order Code	Weight
MULTIEVO2-VP-AT.1h	NM/M	1h	LED	350 lm / 310 lm	LiFePo4 6,4V/1,0Ah	290-B-300-04-00-00	1,5 kg
MULTIEVO2-VP-AT.3h	NM/M	3h	LED	350 lm / 310 lm	LiFePo4 6,4V/2,0Ah	290-B-301-04-00-00	1,6 kg

DALI Self-Contained

Type	Version	Duration	Light Source	Light Flux / Emergency mode	Battery	Order Code	Weight
MULTIEVO2-VP-DALI.1h	NM/M	1h	LED	350 lm / 310 lm	LiFePo4 6,4V/1,0Ah	290-B-308-04-00-00	1,5 kg
MULTIEVO2-VP-DALI.3h	NM/M	3h	LED	350 lm / 310 lm	LiFePo4 6,4V/2,0Ah	290-B-309-04-00-00	1,5 kg

Page No.36

CENTRALTEST -ATXL ELMAX-LOOK

Type	Version	Duration	Light Source	Light Flux / Emergency mode	Battery	Order Code	Weight
MULTIEVO2-VP-ATXL.1h	NM/M	1h	LED	350 lm / 310 lm	LiFePo4 6,4V/1,0Ah	290-B-302-04-00-00	1,6 kg
MULTIEVO2-VP-ATXL.3h	NM/M	3h	LED	350 lm / 310 lm	LiFePo4 6,4V/2,0Ah	290-B-303-04-00-00	1,7 kg

Page No.38

CENTRALTEST -ATRF ELMAX-WIRELESS

Type	Version	Duration	Light Source	Light Flux / Emergency mode	Battery	Order Code	Weight
MULTIEVO2-VP-ATRF.1h	NM/M	1h	LED	350 lm / 310 lm	LiFePo4 6,4V/1,0Ah	290-B-310-04-00-00	1,6 kg
MULTIEVO2-VP-ATRF.3h	NM/M	3h	LED	350 lm / 310 lm	LiFePo4 6,4V/2,0Ah	290-B-311-04-00-00	1,7 kg

DALI CENTRAL BATTERY (CBS)

Type	Version	Light Source	Light Flux	Order Code	Weight
C.EVOLUX2-VP DALI 230V AC	DALI CBS	LED	650 lm	290-B-305-00-00-00	1,2 kg

Page No.44

CENTRAL BATTERY (CBS)

Type	Version	Light Source	Light Flux	Order Code	Weight
C.EVOLUX2-VP 230V AC/DC	CBS NON-ADDRESSABLE	LED	760 lm	290-B-306-00-00-00	1,2 kg
C.EVOLUX2-VP 24V AC/DC	CBS NON-ADDRESSABLE	LED	760 lm	290-B-307-00-00-00	1,2 kg

Page No.40

Addressable CENTRAL BATTERY (CBS) -ATXPR ELMAX-PATROLUX

Type	Version	Light Source	Light Flux	Order Code	Weight
C.EVOLUX2-VP-ATXPR 230V AC/DC	ATXPR CBS ADDRESSABLE	LED	760 lm	290-B-304-00-00-00	1,2 kg

Look up pages No. 210-217 for 1x Spacing tables
 Pozri str.210-217 pre rozmiestnenie svetidiel na dosiahnutie 1x

EVOLUX2-VP/-PP

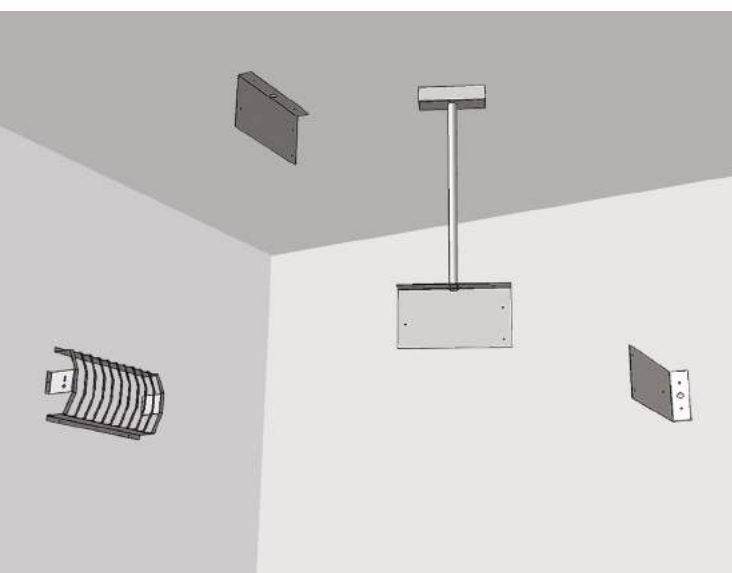

- Suspended plexi with single or double sided legend complying ISO7010
- Viewing Distance: 34m
- AL cover frame for light beam direction to the plexi with legend
- závesné plexi s jednostranným alebo obojstranným piktogramom podľa ISO7010
- rozoznatelnosť piktogramu: 34m
- hliníkový krycí rámik pre nasmerovanie svetla len do plexi hrany

Optional Item / Príplatok	Order Code / Objednávaci kód
Suspended plexi H/J doublesided / obojstranné	102-B-08-11-01
Suspended plexi I doublesided / obojstranné	102-B-08-10-01
Suspended plexi H singlesided / jednostranné	102-B-08-50-00
Suspended plexi I singlesided / jednostranné	102-B-08-51-00
Suspended plexi J singlesided / jednostranné	102-B-08-52-00
Suspended plexi O singlesided / jednostranné	102-B-08-49-00
Suspended plexi O doublesided / obojstranné	102-B-08-47-00
Suspended plexi K/M doublesided / obojstranné	102-B-08-41-01
Suspended plexi L/N doublesided / obojstranné	102-B-08-42-01
Suspended plexi K singlesided / jednostranné	102-B-08-53-00
Suspended plexi L singlesided / jednostranné	102-B-08-54-00
Suspended plexi M singlesided / jednostranné	102-B-08-55-00
Suspended plexi N singlesided / jednostranné	102-B-08-56-00
Suspended plexi Z1 singlesided / jednostranné	102-B-00-57-00
Suspended plexi Z1 doublesided / obojstranné	102-B-00-58-00
Suspended plexi Z2 singlesided / jednostranné	102-B-00-59-00
Suspended plexi Z2 doublesided / obojstranné	102-B-00-60-00
AL cover frame / krycí rámik	102-B-00-27-00

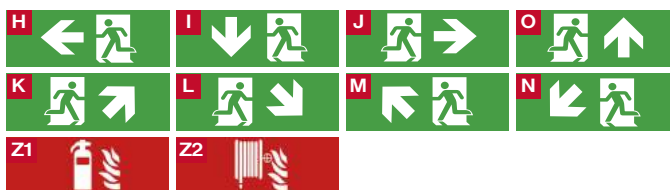
**Options:**

- Wall /Pendant mounting bracket

Príplatky:

- nástenná / závesná konzola

Optional Item Príplatok	Order Code Objednávaci kód
Wall mounting bracket / nástenná konzola RAL9003	102-B-01-09-01
Ceiling mounting bracket / stropná konzola RAL9003	102-B-01-08-01
Pendant bracket 0,5m / závesná konzola 0,5m RAL9003	102-B-28-02-00
Pendant bracket 0,7m / závesná konzola 0,7m RAL9003	102-B-28-05-00
Pendant bracket 0,7m / závesná konzola 0,7m RAL9006	102-B-28-05-01
Pendant bracket 0,75m / závesná konzola 0,75m RAL9006	102-B-28-08-00
Pendant bracket 1,0m / závesná konzola 1,0m RAL9003	102-B-28-03-00
Pendant bracket 1,5m / závesná konzola 1,5m RAL9003	102-B-28-04-00
Pendant bracket 2,25m /závesná konzola 2,25m RAL9003	102-B-28-07-00
Pendant bracket 2,75m /závesná konzola 2,75m RAL9006	102-B-28-11-00
Pendant bracket 3m /závesná konzola 3m RAL9006	102-B-28-10-00
Pendant bracket 3,5m /závesná konzola 3,5m RAL9006	102-B-28-12-00

Shopping area emergency lighting application



RECESSED MOUNTING EVOLUX2-V

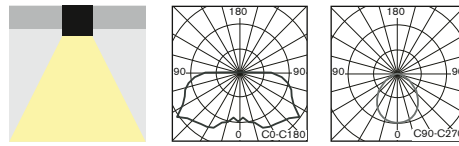

- Equisite design recessed mounted powerful LED fixture with perfect light distribution
- Designed for non-maintained/maintained (NM/M) or centralised (C) emergency lighting available in all following versions:

- **AUTOTEST** (-AT)
- **DALI**
- **CENTRALTEST** (-ATXL) for ELMAX-Look Mini system (look up page No.36)
- **Wireless CENTRALTEST** (-ATRF) for ELMAX-ATRF system (page No.38)
- **CENTRAL BATTERY** (C.EVOLUX2) for **non-addressable CBS** (page 44)
- **CENTRAL BATTERY** (-ATXP) for system **ELMAX-PATROLUX Mini & Addressable CBS** (look up also page No.40)
- Conforming to the requirement of EN60598-2-22, EN1838, EN62034
- Design:
 - Anodized AL base
 - PC impact resistant diffuser

- Elegánntné výkonné LED núdzové svietidlo s perfektnou distribúciou svetla pre trvalé/netrvalé (NM/M) alebo (C) centrálné napájané núdzové osvetlenie dostupné vo verziách pre:

- **AUTOTEST** (-AT)
- **DALI**
- **CENTRALTEST** (-ATXL) pre systém ELMAX-LOOK Mini (pozri str.36)
- **bezdrôtový CENTRALTEST** (-ATRF) pre ELMAX-ATRF systém (str.38)
- **CENTRAL BATTERY** (C.EVOLUX2) pre **neadresovateľné CBS** (str.44)
- **CENTRAL BATTERY** (-ATXP) pre systém **ELMAX-PATROLUX Mini s adresovateľnou CBS** (pozri str.40)

- spĺňa požiadavky európskej normy EN 60598-2-22, EN1838, EN62034
- konštrukcia:
 - teleso z eloxovaného hliníku
 - svetelno-činný kryt z nerozbitného PC

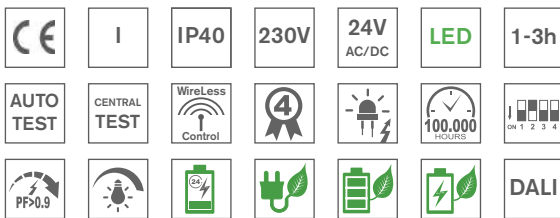

Input Power:

- 5,8W/ 6,1VA (maintained M)
- 2,0W/ 3,9VA (non-maintained NM)
- 5,7W/ 6,0VA (CBS)

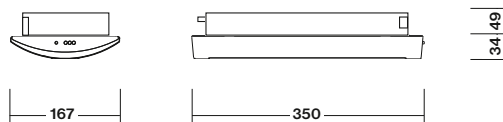

Recessed hole size 319x123mm
Rozmer montážneho otvoru 319x123mm

Most Advanced Twin "V" shaped LED light source for perfect light distribution and high efficiency

Progresívny svetelný zdroj s usporiadaním LED do tvaru "V" s perfektnou distribúciou svetla a vysokou účinnosťou



STANDARD FEATURES

STANDARDNÁ VÝBAVA

- **High efficient (150lm/W) LONGLIFE LEDs 5000K (>100.000h)**
- **NEW Advanced Electronics**
- **LONGLIFE NiMh or LiFePo4 battery**
- **Installation Mode** (battery protection, for more details look up page No.50-51)
- **Intelligent battery charging** (intermittent charging, look up page No.50-51)
- **DIP Switch** allowing to preset following functions:
 - **ECO Mode** (dimming 10%-100%, for more details look up page No.50-51)
 - **ENERGY Saving Mode** (picto illumination 2cd/m² or 200cd/m², look up page No.50-51)
- Special mirror effect reflector
- Addressable CENTRALTEST communication module (for ATXL, ATXP only)
- LEDs indicating both presence of power supply and signaling failures
- TEST button

- **vysoko účinné LED 5000K (150lm/W) so životnosťou min.100000h**
- **progresívna elektronická jednotka**
- **LONGLIFE NiMh alebo LiFePo4 batéria**
- **Inštalčný mód** (ochrana batérie, pozri aj str.50-51)
- **Inteligentné nabíjanie batérie** ("intermittent" nabíjanie, pozri aj str.50-51)
- **DIP prepínač** umožňujúci prednastavenie funkcií:
 - **ECO Mód** (stmievanie 10%-100%, for more details look up page No.50-51)
 - **ENERGY Saving Mód** (osvetlenie pikto na 2cd/m² alebo 200cd/m², pozri aj str.50-51)
- špeciálny odrazový reflektor so zrkadlovým efektom
- adresovateľný CENTRALTEST komunikačný modul (len pre ATXL, ATXP verzie)
- signalizácia LED a TEST tlačítko



Page No.32

AUTOTEST -AT NM/M

Type	Version	Duration	Light Source	Light Flux / Emergency mode	Battery	Order Code	Weight
MULTIEVO2-V-AT.1h	NM/M	1h	LED	350 lm / 310 lm	LiFePo4 6,4V/1,0Ah	290-B-200-04-00-00	1,5 kg
MULTIEVO2-V-AT.3h	NM/M	3h	LED	350 lm / 310 lm	LiFePo4 6,4V/2,0Ah	290-B-201-04-00-00	1,6 kg

DALI Self-Contained

Type	Version	Duration	Light Source	Light Flux / Emergency mode	Battery	Order Code	Weight
MULTIEVO2-V-DALI.1h	NM/M	1h	LED	350 lm / 310 lm	LiFePo4 6,4V/1,0Ah	290-B-208-04-00-00	1,5 kg
MULTIEVO2-V-DALI.3h	NM/M	3h	LED	350 lm / 310 lm	LiFePo4 6,4V/2,0Ah	290-B-209-04-00-00	1,5 kg

Page No.36

CENTRALTEST -ATXL ELMAX-LOOK

Type	Version	Duration	Light Source	Light Flux / Emergency mode	Battery	Order Code	Weight
MULTIEVO2-V-ATXL.1h	NM/M	1h	LED	350 lm / 310 lm	LiFePo4 6,4V/1,0Ah	290-B-202-04-00-00	1,6 kg
MULTIEVO2-V-ATXL.3h	NM/M	3h	LED	350 lm / 310 lm	LiFePo4 6,4V/2,0Ah	290-B-203-04-00-00	1,7 kg

Page No.38

CENTRALTEST -ATRF ELMAX-WIRELESS

Type	Version	Duration	Light Source	Light Flux / Emergency mode	Battery	Order Code	Weight
MULTIEVO2-V-ATRF.1h	NM/M	1h	LED	350 lm / 310 lm	LiFePo4 6,4V/1,0Ah	290-B-210-04-00-00	1,6 kg
MULTIEVO2-V-ATRF.3h	NM/M	3h	LED	350 lm / 310 lm	LiFePo4 6,4V/2,0Ah	290-B-211-04-00-00	1,7 kg

DALI CENTRAL BATTERY (CBS)

Type	Version	Light Source	Light Flux	Order Code	Weight
C.EVOLUX2-V DALI 230V AC	DALI CBS	LED	650 lm	290-B-205-04-00-00	1,2 kg

Page No.44

CENTRAL BATTERY (CBS)

Type	Version	Light Source	Light Flux	Order Code	Weight
C.EVOLUX2-V 230V AC/DC	CBS NON-ADDRESSABLE	LED	760 lm	290-B-206-00-00-00	1,2 kg
C.EVOLUX2-V 24V AC/DC	CBS NON-ADDRESSABLE	LED	760 lm	290-B-207-00-00-00	1,2 kg

Page No.40

Addressable CENTRAL BATTERY (CBS) -ATXPR ELMAX-PATROLUX

Type	Version	Light Source	Light Flux	Order Code	Weight
C.EVOLUX2-V-ATXPR 230V AC/DC	ATXPR CBS ADDRESSABLE	LED	760 lm	290-B-204-00-00-00	1,2 kg

Look up pages No. 210-217 for 1lx Spacing tables
Pozri str.210-217 pre rozmiestnenie svetidiel na dosiahnutie 1lx